

SYSTIMAX[®] MGS Module Termination Instructions

General

These instructions provide the recommended termination procedure for all **SYSTIMAX[®]** MGS-type modules. MGS600 modules are illustrated here, but instructions also apply to MGS400 and MGS500 modules. The MGS modules are **UL** approved. Preparation of the new **SYSTIMAX GigaSPEED[®] X10D 91B series cable, 95B series cordage, or Xpress[®] 88 series cable** is also shown. For complete instructions on prepping the **GigaSPEED X10D 91B series cable, 95B series cordage, or Xpress 88 series cable** for termination, see instruction sheet 860 469 402.

Refer to the **SYSTIMAX X10D** Design and Installation Guidelines for further information.

The following tools are available to aid in module termination.

Material ID	Description
406477794	D-914 kit - includes impact tool and 110 blade
407484971	D-914 impact tool only
407728427	Replacement 110 blade for D-914 impact tool
760122713	Module removal tool (quantity of 5)
860251081	Hand termination tool (hand puck)
405423260	KS-22035-L2 spudger tool

How to Contact Us

- To find out more about **SYSTIMAX[®]** Solutions, visit us on the web at <http://www.commscope.com/systimax>
- For technical assistance regarding **SYSTIMAX** products:
 - Within the United States, contact your local account representative or **SYSTIMAX** technical support at 1-800-344-0223. Outside the United States, contact your local account representative or Authorized Business Partner.
 - Within the United States, report any missing or damaged parts to **SYSTIMAX** Customer Service in Omaha, NE, at 1-866-539-2795. Outside the United States, contact your local account representative or Authorized Business Partner.

Preparation of X10D 91B Series Cable, 95B Series Cordage, or Xpress 88 Series Cable for Termination

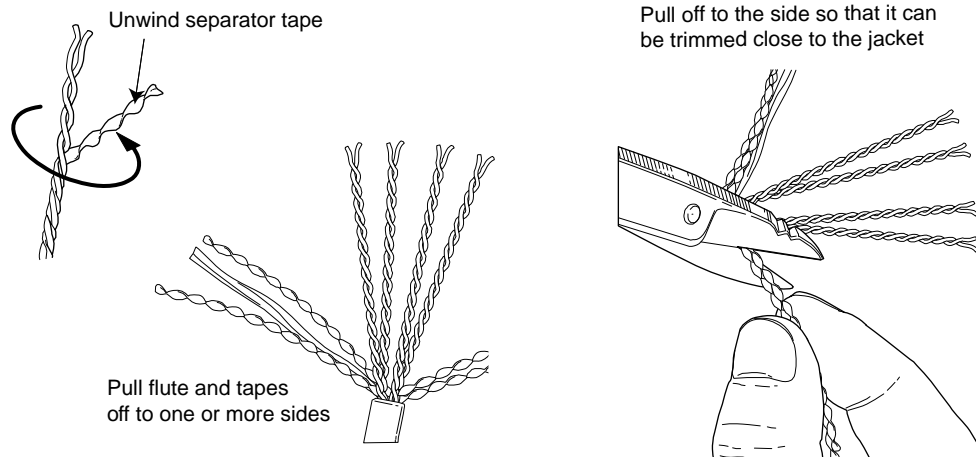

Termination Procedure

T568B Wiring Shown

Pre-Termination Step For Angled Entry

Note: Some mounting hardware and box space does not allow for cable entry directly from the rear. If a typical termination from the rear is done and the cable is then bent in the needed direction, performance and reliability can suffer. A proper termination should have the intended entry direction set before seating the conductors.

1. Set the intended entry angle before seating the conductors.
2. Pull pairs into the module until the jacket is snug against the rear housing. Outer pairs should sweep around the inside pairs and not be pulled into them.

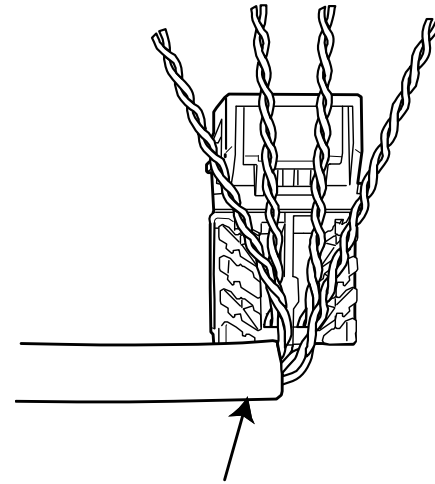

Cable positioned at 90° prior to seating conductors

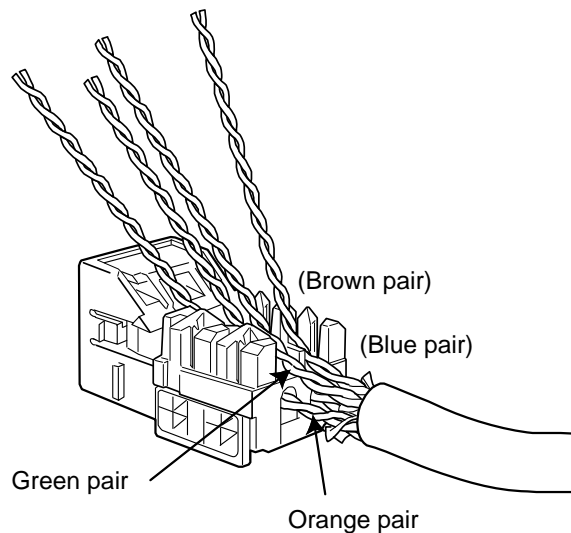

Direct Cable End

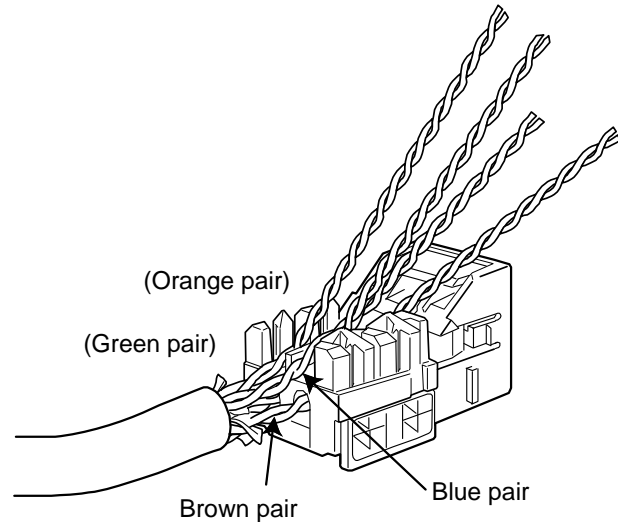

Reverse Cable End

1. Each cable end has two pairs routed into the holes and two pairs routed over the top, without crossover or rearrangement. On the **Direct** cable end, the Orange and Blue pairs enter the holes and the Green and Brown pairs lay over the top. On the **Reverse** cable end, the Green and Brown pairs enter the holes and the Orange and Blue pairs lay over the top.
2. Pull pairs into the module until the jacket end is snug against the rear housing.

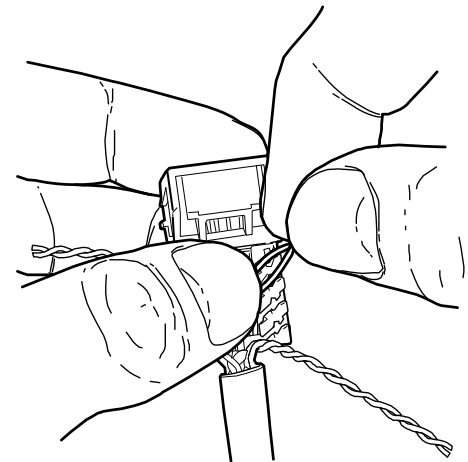
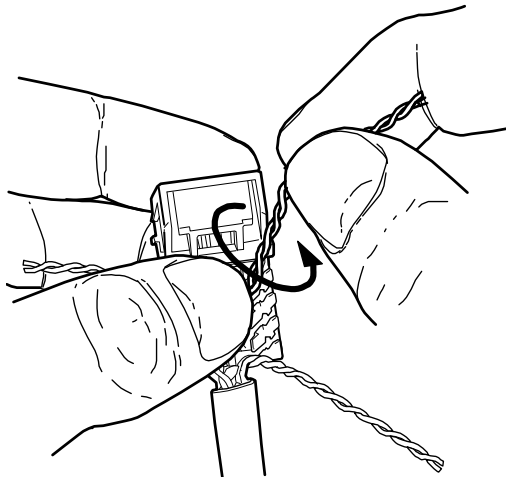

3. To place conductors, hold the pair down on the termination position and bend it for easy grasp as shown above. Then untwist the pair in a counter-clockwise direction enough to open it up.

4. Push conductors down into slot positions (check color codes). Maintain pair twist up to the opening for the slots.

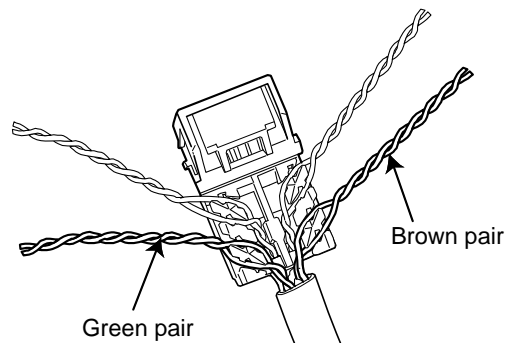
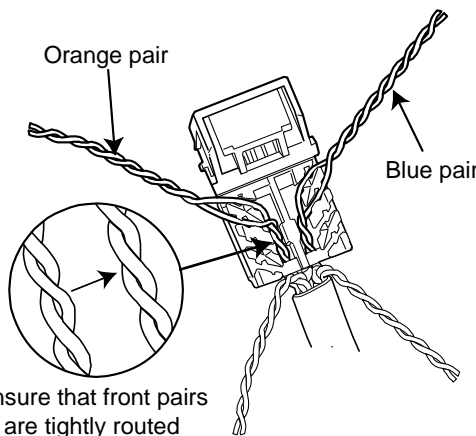

5. (T568B wiring shown) On the **Direct** cable end, place Orange and Blue pairs first, then place Green and Brown pairs.

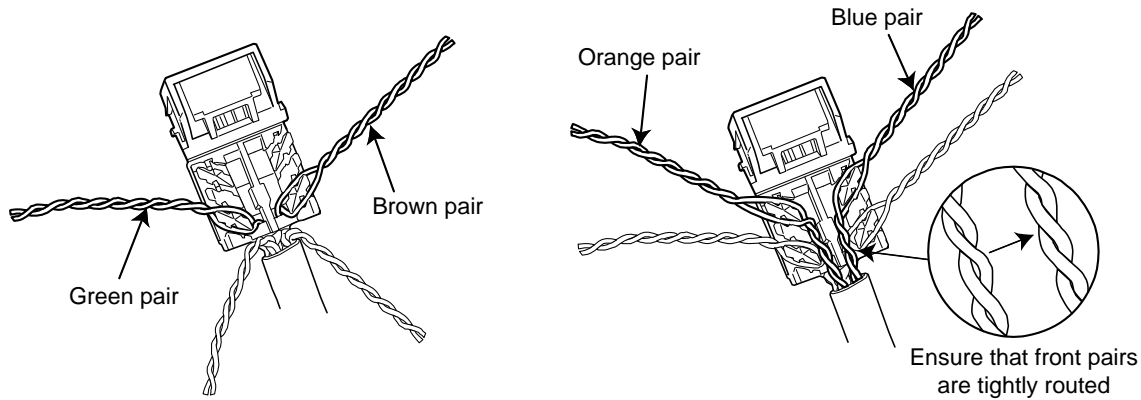

6. (T568B wiring shown) On the **Reverse** cable end, pull Green and Brown pairs back, eliminate the twist, and pull them tightly into place. Then route Orange and Blue pairs to the front positions.

Note: For T568A Wiring -

On each cable end, one of the two pairs fed in through the holes is pulled back for the rear positions. Check label color codes.

Conductor Seating and Cutting

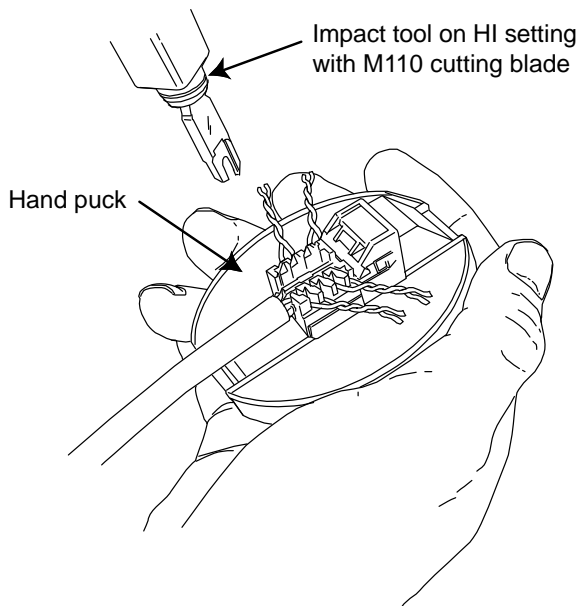

1. Use impact tool on HI setting with M110 cutting blade to punch conductors straight down into slots. When using the impact tool, the hand puck is recommended.

Or

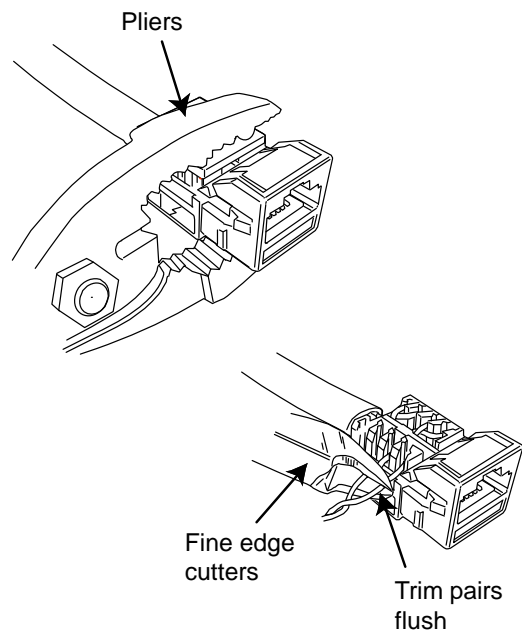

2. Use pliers with wire cap to seat conductors. Use fine edge cutters to trim conductors flush to the module body.

Module Removal

1. To remove a module for inspection or repair, insert prongs of removal tool into openings at sides of module and press firmly.

Or

The module wiring cap can also be used to remove a module. Insert prongs of cap into openings at sides of module and press firmly.

2. The module can then be removed from the back.

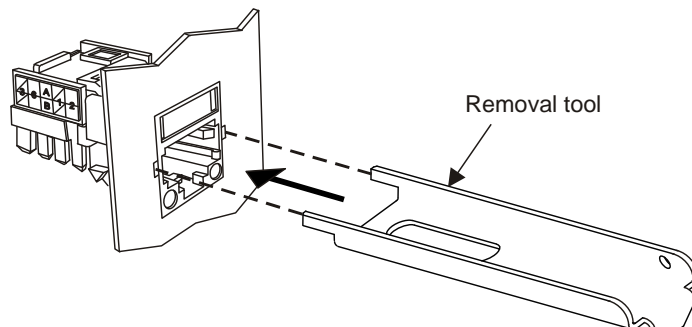

Inspection or Repair of Termination

Note: To enable inspection or repair, the wiring cap can be released from the module using the removal tool. A spudger tool can then be used to remove conductors for repair.

1. Insert end of removal tool into slot under wiring cap and pivot it forward to release cap.

